

FLUID PUMP



*Submersible Pump & Mixer
Manufacturer.*

V
X
R
A
N
G
E

65
80
100
125
150
200

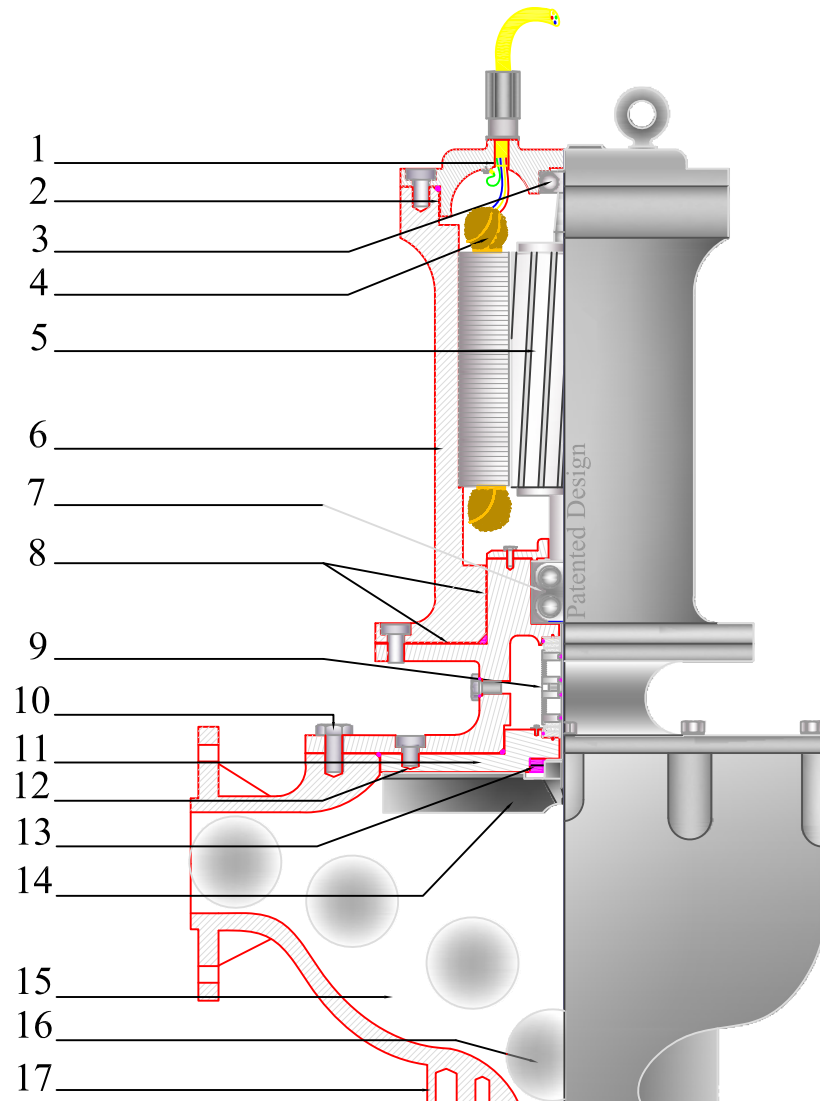

Features:

1. Epoxy Potted - Cable Seal
2. Sturdy Design Ex Approval, Tolerances ISO H7
3. Angular Contact - C3 Bearing # B12
4. Motor Winding Class H 180°C
5. Rotating Assembly Balanced to ISO 1940/1 G2.5
6. Open Stator Housing
7. Double Angular Contact Bearing - C3 # B12
8. Sturdy Spigot, Heat sink, Ex Approval, Tolerances ISO H7
9. Quarto Mechanical Seal TC/TC in Oil - Out of Product
10. Easy Reconcilable for Volute Opening Only
11. Replaceable Back Cover
12. No Cavities in Volute Area
13. Double Primary Seals around Impeller Neck
14. Multiple " VORTEX " Recessed Impeller Options
15. Reduced Volute Area " PREVENT VORTEX CLOG "
16. Large Through let : 65, 80, 100, 125, 150 mmØ
17. Material Options GG25, SG60, CrMO102
18. Freestanding or Under Water Quick Coupler